

Aruba 7205 Controller



Installation Guide

Copyright Information

© 2015 Aruba Networks, Inc. Aruba Networks trademarks include  **airwave**, Aruba Networks[®], Aruba Wireless Networks[®], the registered Aruba the Mobile Edge Company logo, Aruba Mobility Management System[®], Mobile Edge Architecture[®], People Move. Networks Must Follow[®], RFProtect[®], Green Island[®]. All rights reserved. All other trademarks are the property of their respective owners.

Open Source Code

Certain Aruba products include Open Source software code developed by third parties, including software code subject to the GNU General Public License (GPL), GNU Lesser General Public License (LGPL), or other Open Source Licenses. Includes software from Litech Systems Design. The IF-MAP client library copyright 2011 Infoblox, Inc. All rights reserved. This product includes software developed by Lars Fenneberg et al. The Open Source code used can be found at this site

http://www.arubanetworks.com/open_source

Legal Notice

The use of Aruba Networks, Inc. switching platforms and software, by all individuals or corporations, to terminate other vendors' VPN client devices constitutes complete acceptance of liability by that individual or corporation for this action and indemnifies, in full, Aruba Networks, Inc. from any and all legal actions that might be taken against it with respect to infringement of copyright on behalf of those vendors.

Warranty

This hardware product is protected by an Aruba warranty. For more information, refer to the ArubaCare service and support terms and conditions.

Contents	3
Preface	7
Guide Overview	7
Related Documentation	7
Contacting Support	7
7205 Controller	9
Packaging Checklist	9
7205 Components	10
Dual-Media Ports	11
10/100/1000BASE-T (RJ-45) Ports	11
1000BASE-X (SFP) Ports	12
Dual-Media Port LEDs	12
10GBASE-X Ports	13
SFP/SFP+ Modules and DAC Cables	14
USB Interface	15
Serial Console Port	15
Serial Console Port Adapter	16
Micro-USB Console Port	16
Micro-USB Driver	16
Management Port	16
Power, Status, and Peered LEDs	17
LCD Panel	17
LCD Menu	17
Disabling the LCD Screen	18
CPU Module	19

Power Supply	19
Grounding Point	19
Installation	21
Precautions	21
Selecting a Location	21
Rack Mounting - Standard/Front	22
Required Tools and Equipment	22
Installation Steps	22
Rack Mount Installation- Mid	23
Required Tools and Equipment	24
Installation Steps	24
Table or Shelf Installation	25
Required Tools and Equipment	25
Installation Steps	25
Wall Mounting	26
Required Tools and Equipment	26
Installation Steps	26
Connecting and Disconnecting the AC Power Cord	27
Connecting the AC Power Cord	27
Disconnecting the AC Power Cord	28
Installing an SFP/SFP+ Module	28
Connecting an LC Fiber Optic Cable	28
Disconnecting an LC Fiber Optic Cable	29
Removing an SFP/SFP+ Module	29
Specifications, Safety, and Compliance	31
7205 Specifications	31
Physical	31
Power Supply Specifications	31

Operating Specifications	31
Storage Specifications	31
Safety and Regulatory Compliance	31
Regulatory Model Name	32
Electromagnetic Interference	32
United States	32
Canada	32
Europe	33
Japan VCCI	33
Taiwan (BSMI)	33
South Korea	33
EU Regulatory Conformance	33
Battery Statements	33
Proper Disposal of Aruba Equipment	34
Waste of Electrical and Electronic Equipment	34
China RoHS	34
European Union RoHS	34
India RoHS	35

This document describes the hardware features of the Aruba 7205 Controller. It provides a detailed overview of the physical and performance characteristics of the controller and explains how to install the controller and its accessories.

Guide Overview

- [7205 Controller on page 9](#) provides a detailed hardware overview of the 7205 controller and its components.
- [Installation on page 21](#) describes how to install the 7205 controller and its components.
- [Specifications, Safety, and Compliance on page 31](#) provides the 7205 controller's technical specifications and safety and regulatory compliance information.

Related Documentation

Refer to the latest *ArubaOS User Guide* and *ArubaOS CLI Reference Guide* for complete management of the controller.

The latest documentation and the translation of this document into other languages can be found at www.arubanetworks.com/documentation.

Contacting Support

Table 1: *Contact Information*

Main Site	arubanetworks.com
Support Site	support.arubanetworks.com
Airheads Social Forums and Knowledge Base	community.arubanetworks.com
North American Telephone	1-800-943-4526 (Toll Free) 1-408-754-1200
International Telephone	http://www.arubanetworks.com/support-services/support-program/contact-support/
Software Licensing Site	https://licensing.arubanetworks.com/
End of Support Information	http://www.arubanetworks.com/support-services/end-of-life-products/end-of-life-policy/
Wireless Security Incident Response Team (WSIRT)	http://www.arubanetworks.com/support-services/security-bulletins/

Support Email Addresses	
Americas, EMEA, and APAC	support@arubanetworks.com
Security Incident Response Team (SIRT)	sirt@arubanetworks.com

The 7205 Controller is a wireless LAN controller that connects, controls, and intelligently integrates wireless Access Points (APs) and Air Monitors (AMs) into a wired LAN system.

There are two models of the 7205 controller that do not differ physically or functionally from each other.

- 7205-US: For the United States of America
- 7205-RW: For the rest of the world

The 7205 controller has the following port specification:

Table 2: 7205 Controller Port Specification

Model	Ports	Number of APs Supported	Number of Users Supported
7205	<ul style="list-style-type: none"> • 4 x dual-media (10/100/1000BASE-T and 1000BASE-X) • 2 x 10GBASE-X 	256	8192



The 7205 controller requires ArubaOS 6.4.3.1 or later version.

Packaging Checklist



Inform your supplier if there are any incorrect, missing, or damaged parts. If possible, retain the carton, including the original packing materials. Use these materials to repack and return the unit to the supplier, if needed.

Table 3: Package Contents

Item	Quantity
7205 Controller	1
Standard Mounting Brackets	2
M6 x 15 mm Phillips Pan Head Screws	4
M4 x 8 mm Phillips Flat Head Screws	8
M6 x 7 mm Grounding Screws	2
AC Power Cord Retaining Clip	1
Power Cable	1
Micro-USB Cable	1
Rubber Feet	4

Table 3: Package Contents

Item	Quantity
Installation Guide (this document, printed)	1
Quick Start Guide (Printed)	1
End User License Agreement (printed)	1



Optional accessories are available for use with the Aruba 7205 controller and are sold separately. Contact your Aruba sales representative for details and assistance.

7205 Components

This section introduces the different components of the 7205 controller, and specifies their locations in the controller. [Figure 1](#) shows the front panel of the 7205 controller and [Figure 2](#) shows the back panel of the 7205 controller.

Figure 1 Front Panel of the 7205 Controller

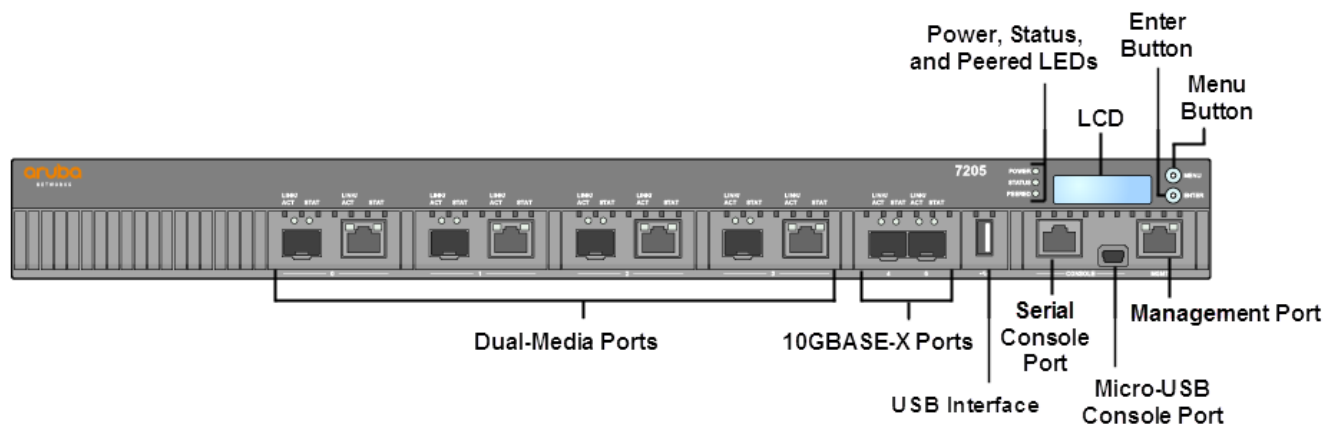
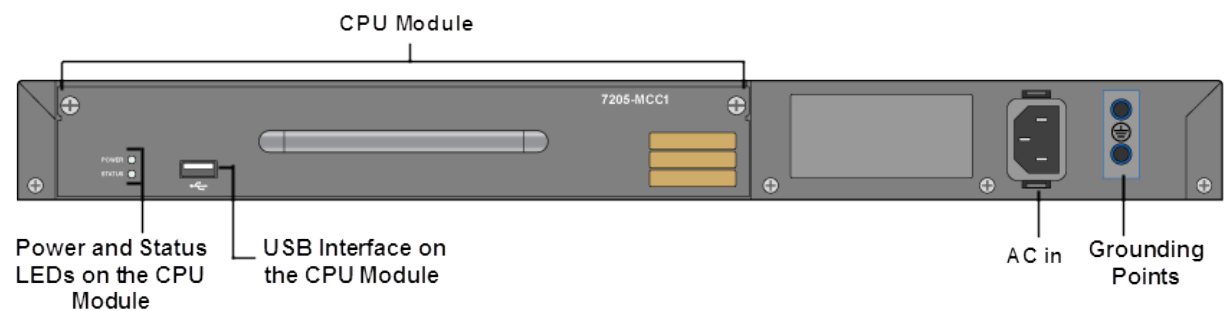

Figure 2 Back Panel of the 7205 Controller



The following table lists the different components of the 7205 controller:

Table 4: 7205 Controller Components

Component	Description	Page
Dual-Media ports	4 x dual-media (10/100/1000BASE-T and 1000BASE-X) ports	11
10GBASE-X ports	2 x 10GBASE-X ports	13
USB interface	Allows uploading configuration and image from a USB 2.0 storage device.	15
Serial console port	RJ-45 serial console access port for direct local management	15
Micro-USB console port	Micro-USB console access port for direct local management	16
Management port	Allows connection to a separate management network	16
Power, Status, and Peered LED	Provides basic monitoring of the controller	17
LCD	Allows configuration of LCD behavior and other basic operations	17
Enter button	Allows execution of actions on the LCD Screen	
Menu button	Allows selection of the LCD screen menu	
CPU Module	CPU module	19
Power and Status LEDs on the CPU module	Provides basic monitoring of the CPU module	
USB Interface on the CPU module	Serves the same purpose as the USB interface on the front panel	
AC in	AC power connector	19
Grounding points	Provided for attaching the grounding	19

Dual-Media Ports

The 7205 controller is equipped with four sets of dual-media ports (ports 0 through 3). These ports can utilize either a 1000BASE-X or 10/100/1000BASE-T connection provided. However, the 1000BASE-X fiber connection has priority over the 10/100/1000BASE-T copper connection. If a link is detected on the 1000BASE-X interface, the 10/100/1000BASE-T connection will be disabled.

10/100/1000BASE-T (RJ-45) Ports

The 7205 controller is equipped with four 10/100/1000BASE-T copper ports, as a part of dual-media ports. Gigabit Ethernet uses all eight wires and each pair is used in a bi-directional fashion, meaning the same pairs are used for both data transmission and reception. [Figure 3](#) illustrates the CAT-5 pin-out on an RJ-45 connector. The CAT-5 pin-out pairs the following pins on a 10/100/1000BASE-T Gigabit Ethernet port: 1/2, 3/6, 4/5, and 7/8.

Figure 3 10/100/1000BASE-T Port Pin Out

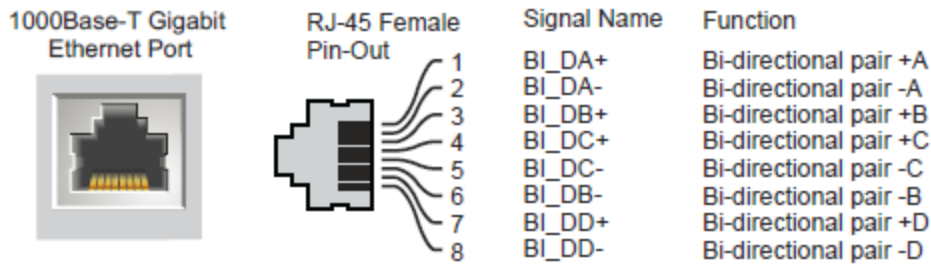

1000BASE-X (SFP) Ports

The 7205 controller is equipped with four 1000BASE-X dual-media ports for fiber connectivity only and are intended for use with SFPs (mini-GBICs).



Aruba tests and supports Aruba optics within their controller systems. Third party optics are not tested or supported; therefore, Aruba does not guarantee proper functionality of third party optics when used in an Aruba system.

Dual-Media Port LEDs

Each port is equipped with two LEDs that allow basic monitoring of status, activity, and configuration of the port.

- **LINK/ACT**— Placed above the port to the left, this LED displays the link status and activity of the port.
- **STATUS**— Placed above the port to the right, this LED displays the status of the port. The information displayed by this LED changes based on the LCD mode. The LED behavior corresponding to each LCD mode is listed in [Table 5](#) and [Table 6](#).

Table 5: 10/100/1000BASE-T Port LEDs

LED	Function	LCD Mode	Indicator	Status
LINK/ACT	Link status	Link status	Green (Solid)	Link established
			Green (Blinking)	Port is transmitting or receiving data
			Off	No link
STATUS	Port status	Administrative	Green (Solid)	Port enabled
			Off	Port administratively disabled
		Duplex	Green (Solid)	Full-duplex
			Off	Half-duplex
		Speed	Green (Solid)	1000 Mbps
			Off	10/100 Mbps

Table 6: 1000BASE-X Port LEDs

LED	Function	LCD Mode	Indicator	Status
LINK/ACT	Link status	Link status	Green (Solid)	Link established
			Green (Blinking)	Port is transmitting or receiving data
			Off	No link
STATUS	Port status	Administrative	Green (Solid)	Port enabled
			Off	Port administratively disabled
		Duplex	Green (Solid)	Full-duplex
			Off	NA
		Speed	Green (Solid)	1 Gbps
			Off	NA

10GBASE-X Ports

The 7205 controller is equipped with two 10GBASE-X (SFP+) ports (4 and 5). These ports are intended for use with SFP/SFP+ and support dual-speed (1GbE or 10GbE) operation.

Figure 4 10GBASE-X Ports and LEDs

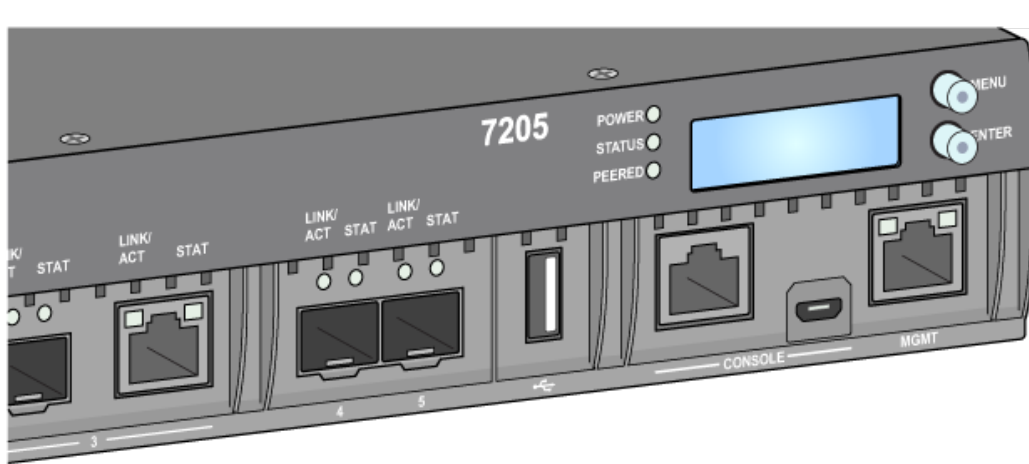

Aruba tests and supports Aruba optics within their controller systems. Third party optics are not tested or supported; therefore, Aruba does not guarantee proper functionality of third party optics when used in an Aruba system.

Each port is equipped two LEDs that allow basic monitoring of status, activity, and configuration of the port.

- **LINK/ACT**— Placed to the top left of the port, this LED displays the link status and activity of the port.
- **STATUS**— Placed to the top right of the port, this LED displays the status of the port. The information displayed by this LED changes based on the LCD mode. The LED behavior corresponding to each LCD mode is listed in [Table 7](#).

Table 7: 10GBASE-X Port LEDs

LED	Function	LCD Mode	Indicator	Status
LINK/ACT	Link status	NA	Green (Solid)	Link established
			Green (Blinking)	Port is transmitting or receiving data
			Off	No link
STATUS	Port status	Administrative	Green (Solid)	Port enabled
			Off	Port administratively disabled
		Duplex	Green (Solid)	Full-duplex
			Off	NA
		Speed	Green (Solid)	10 Gbps
			Off	1 Gbps

SFP/SFP+ Modules and DAC Cables

SFP/SFP+ modules (purchased separately), also known as mini-GBICs are hot-swappable, provide optical or copper connections to other devices.

Direct attach cables (DACs) are installed in a 10GBASE-X port in the same manner as an SFP/SFP+ module.

For the list of Aruba approved SFP/SFP+ modules and DAC cables for controllers, see [Table 8](#) and [Table 9](#).



Other non-approved third-party optics or DAC cables are not tested or supported by Aruba on controllers; therefore, Aruba does not guarantee their proper functionality when used with Aruba controllers.



SFP/SFP+ Modules and DAC cables are sold separately. Contact your Aruba sales representative for details and assistance.

For information on how to install an SFP/SFP+ module or a DAC cable, see [Installing an SFP/SFP+ Module on page 28](#).

Table 8: Supported SFP/SFP+ Modules

SFP/SFP+	Description
SFP-SX	SFP, 1000BASE-SX, LC Connector; 850nm pluggable GbE optic; up to 300 meters over multi-mode fiber (Type OM2).
SFP-LX	SFP, 1000BASE-LX, LC Connector; 310nm pluggable GbE optic; up to 10,000 meters over single-mode fiber.
SFP-TX	SFP, 1000BASE-T SFP; copper GbE pluggable; RJ45 connector; up to 100 meters over Category-5, 5e, 6 and 6a unshielded twisted pair cable. NOTE: Supported only in ports 4 and 5.
SFP-EX	1000BASE-ZX SFP; 1310nm pluggable GbE optic; LC connector; up to 40,000 meters over single-mode fiber

Table 8: Supported SFP/SFP+ Modules

SFP/SFP+	Description
SFP-ZX	1000BASE-ZX SFP; 1310nm pluggable GbE optic; LC connector; up to 70,000 meters over single-mode fiber
SFP-10G-SR	SFP+, 10GBASE-SR, 850nm serial pluggable SFP+ optic, target range 300m over MMF, LC Connector.
SFP-10G-LR	SFP+, 10GBASE-LR, 1310nm serial pluggable SFP+ optic for up to 10km over SMF, LC Connector
SFP-10G-LRM	SFP+, 10GBASE-LRM, 1310nm serial pluggable SFP+ optic, long-reach multimode, LC Connector
SFP-10G-ER	SFP+, 10GBASE-ER, 1310nm pluggable 10GE optic; up to 40,000 meters over single-mode fiber, LC connector
SFP-10G-ZR	SFP+, 10GBASE-ZR, 1310nm pluggable 10GE optic; up to 70,000 meters over single-mode fiber, LC connector

Table 9: Supported DAC Cables

DAC	Description
DAC-SFP-10GE-50CM	50cm Direct Attach Cable; 10G SFP+
DAC-SFP-10GE-1M	1m Direct Attach Cable; 10G SFP+
DAC-SFP-10GE-3M	3m Direct Attach Cable; 10G SFP+
DAC-SFP-10GE-5M	5m Direct Attach Cable; 10G SFP+
DAC-SFP-10GE-7M	7m Direct Attach Cable; 10G SFP+

USB Interface

The 7205 controller is equipped with two USB 2.0 interfaces; one on the front panel of the controller and the other on the CPU module in the back panel of the controller. A USB storage device can be used to save configurations, upload configurations, and upgrade image to the controller. USB functions are controlled through the LCD panel on the front of the controller. For more information on the LCD panel and its functions, see [LCD Panel on page 17](#).

Serial Console Port

For direct local management of the controller, use the serial console port located on the front (see [Figure 5](#)). This port is an RJ-45 female connector that accepts an RS-232 serial cable with a male connector.

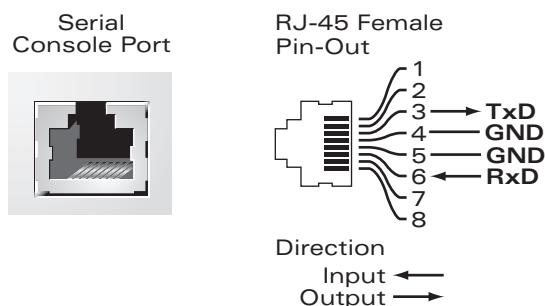
Figure 5 Serial Console Port Pin-Out

The communication settings for the console port are shown in the following table:

Table 10: Console Terminal Settings

Baud Rate	Data Bits	Parity	Stop Bits	Flow Control
9600	8	None	1	None



The Console port is compatible only with RS-232 devices. Non-RS-232 devices, such as APs, are not supported.

Do not connect the Console port to an Ethernet switch or a PoE power source. This may damage the controller.



Le port CONSOLE est compatible uniquement avec les périphériques RS-232. Les périphériques qui ne sont pas de type RS-232, notamment les points d'accès, ne sont pas pris en charge.

Ne connectez pas le port Console sur un commutateur Ethernet ou une source d'alimentation PoE. Sinon, vous risquez d'endommager le contrôleur.

Serial Console Port Adapter

A modular adapter can be used to convert the female RJ-45 connector on the front (see [Figure 5](#)) to a male DB9 connector. See [Figure 6](#) for details.

Figure 6 RJ-45 (Female) to DB9 (Male) Modular Adapter Conversion

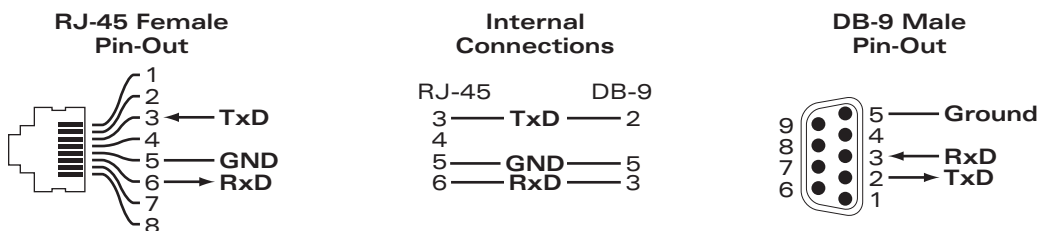

Micro-USB Console Port

The 7205 controller is equipped with one Micro-USB (type B) connector on the front (see [Figure 4](#)) that provides console access for direct local management. If both Micro-USB and RJ-45 Console ports are connected, the Micro-USB connection takes precedence over the RJ-45 Console connection.

Micro-USB Driver

To use the Micro-USB console port, install the Micro-USB driver on the system that will manage the controller. To download the driver, perform the following steps:

1. Go to <https://support.arubanetworks.com>.
2. Click on the **Tools & Resources** tab.
3. Open the **USB Console Driver** folder.
4. Open the **Mobility Controller and Mobility Access Switch** folder.
5. Select the appropriate file for your application. The corresponding operating system is in the file name.

Management Port

The 7205 controller is equipped with a 10/100/1000BASE-T Gigabit Management (RJ-45) port on the front (see [Figure 4](#)). The management port provides 10/100/1000 Mbps Ethernet access to the controller CLI, SNMP, and Web interface for complete system management and troubleshooting. It can also be used to connect to a

separate management network. The management port has a LINK/ACT LED on its top left and SPEED LED on its top right. During operation, these LEDs provide the status information as shown in the following table:

Table 11: 10/100/1000BASE-T (RJ-45) Management Port

LED	Function	Indicator	Status
LINK/ACT	Link Status	Green (Solid)	Link established
		Green (Blinking)	Link activity
		Off	No link on port
SPEED	Interface Speed	Green (Solid)	1000 Mbps
		Off	10/100 Mbps

Power, Status, and Peered LEDs

The front panel of the controller also includes Power, Status, and Peered LEDs (see [Figure 4](#)) that provide basic monitoring of the overall status of the controller. The following table describes the different behavior of these LEDs:

Table 12: Power, Status, and Peered LEDs

LED	Function	Indicator	Status
Power	System Power	Green (Solid)	Power On
		Off	Power Off
Status	System Status	Green (Solid)	Operational
		Green (Blinking)	Device is loading software
		Amber (Blinking)	Major alarm
		Amber (Solid)	Critical alarm
		Off	No power
Peered	Reserved for future use	NA	NA

LCD Panel

The 7205 controller is equipped with an LCD panel that displays information about the controller's status, and provides a menu that allows basic operations, such as initial setup and reboot. The LCD panel displays two lines of text with a maximum of 16 characters per line. When using the LCD panel, the active line is indicated by an arrow next to the first letter. The LCD panel is operated using the two navigation buttons to the right of the screen. See [Figure 4](#).

- Menu— Allows navigation through the menus of the LCD panel
- Enter— Confirms and executes the action currently displayed on the LCD panel

LCD Menu

The LCD menu includes four modes as shown in the following table:

Table 13: LCD Panel Mode

LCD Mode	Function	Displayed Status/Command	Description
Boot	Displays boot status of the controller	Booting ArubaOS...	Boot status of the controller.
LED	Displays the mode of the STATUS LED of ports. The LED mode menu allows to choose what information is communicated by the STATUS LEDs on each port. See Table 5 for descriptions of the LED behavior of each mode.	LED mode: ADM	Administrative– Displays whether the port is administratively enabled or disabled
		LED mode: DPX	Duplex– Displays the duplex mode of the port
		LED mode: SPD	Speed– Displays the speed of the port.
		Exit	Exit LED menu
Status	Displays the ArubaOS version.	OS Version	ArubaOS version
		Exit	Exit Status menu
Maintenance	Allows execution of some basic operations such as uploading an image or rebooting the controller	Upgrade Image [Partition 0 [Y N] Partition 1 [Y N]]	Upgrade the controller image on the selected partition from a predefined location on an attached USB flash device
		Upload config [Y N]	Upload the controller's current configuration to a predefined location on the attached USB flash device
		Factory Default [Y N]	Reset the controller to factory default settings
		Media Eject [Y N]	Complete reading or writing to the attached USB device
		Reload system [Y N]	Reload controller
		Halt system [Y N]	Halt controller
		Exit	Exit Maintenance menu

Disabling the LCD Screen

By default, the LCD screen is enabled. However, if the 7205 controller is deployed in a location without physical security, the LCD screen can be disabled through the CLI. When disabled, pushing one of the navigation buttons will only illuminate the LCD screen and display the slot, role, device name, and any alarms.

Additionally, it is possible to disable only the maintenance menu. This allows to change the LED behavior and view the device status but prevent upgrades and configuration changes.

To disable the LCD screen, enter the Enable mode and use the following CLI commands:

```
(host) #configure terminal
(host) (config) #lcd-menu
(host) (lcd-menu) #disable menu
```

To disable only the Maintenance menu or one of its sub-menus, enter the Enable mode and use the following CLI commands:

```
(host) #configure terminal
(host) (config) #lcd
(host) (lcd-menu) #disable menu maintenance ?
    factory-default
    halt-system
    media-eject
    reload-system
    upgrade-image
    upload-config
(host) (lcd-menu) #disable menu maintenance upgrade-image ?
    partition0
    partition1
```

CPU Module

The 7205 controller is equipped with a pre-installed CPU module on the back panel of the controller.



Do not remove the CPU module unless directed by an authorized Aruba technician. The CPU module is not hot-swappable.

For LED behavior on the CPU module, see [Table 14](#).

Table 14: *Power and Status LEDs on the CPU Module*

LED	Function	Indicator	Status
Power	CPU Power	Green (Solid)	Module power On
		Off	Power Off
Status	CPU Status	Green (Solid)	Module operational
		Green (Blinking)	Device is loading software
		Off	No power

Power Supply

The 7205 controller is equipped with an integrated AC power supply of 180W.

Grounding Point

To meet safety and electromagnetic interference (EMI) requirements and to ensure proper operation, the controller must be adequately grounded before power is connected. Connect a grounding cable to earth ground and then attach it to the chassis grounding point using two screws.

Comply with electrical grounding standards during all phases of installation and operation of the product. Do not allow the controller's chassis, network ports, power supply, or mounting brackets to contact any device, cable, object, or person attached to a different electrical ground. Also, never connect the device to external storm grounding sources.

This chapter describes how to install a 7205 controller using the different mounting options available. The 7205 controller ships with an accessory kit that includes the equipment needed to mount the controller in a standard two-post 19-inch Telco rack.



Only use the included or Aruba specified cables, power cords, AC power supplies, and batteries. The power cord should not be used with other electric equipment than what is specified by Aruba.



Utilisez uniquement les câbles, cordons d'alimentation, alimentations c.a. et batteries inclus ou les câbles, cordons d'alimentation, alimentations c.a. et batteries spécifiés par Aruba. Le cordon d'alimentation ne doit pas être utilisé avec des équipements électriques autres que ceux spécifiés par Aruba.



接続ケーブル、電源コード、ACアダプタ、バッテリーなどの部品は、必ず添付品または指定品をご使用ください。また、電源ケーブルは弊社が指定する製品以外の電気機器には使用できないためご注意ください。

Precautions

- Ensure that the rack is correctly and securely installed to prevent it from falling or becoming unstable.
- Dangerous voltage above 240VAC is always present while the Aruba Power Supply Module is plugged into an electrical outlet. Remove all rings, jewelry, and other potentially conductive material before working with this device.
- Never insert foreign objects into the chassis, power supply, or any other component, even when the power supply is turned Off, unplugged, or removed.
- Ensure that the main power is fully disconnected from the controller by unplugging all power cords from their outlets. For safety, verify that the power outlets and plugs are easily reachable by the operator.
- Do not handle electrical cables which are not insulated. This also includes network cables.
- Keep water and other fluids away from the controller to minimize electrical hazards.
- Comply with electrical grounding standards during all phases of installation and operation of the product. Do not allow the controller's chassis, network ports, power supply, or mounting brackets to contact any device, cable, object, or person attached to a different electrical ground. Also, never connect the device to external storm grounding sources.
- Perform installation or removal of the chassis or any module in a static-free environment. Proper use of antistatic body straps and mats is strongly recommended.
- Modules must be kept in anti-static packaging when not installed in the chassis.
- Do not ship or store this product near strong electromagnetic, electrostatic, magnetic, or radioactive fields.
- Do not disassemble the chassis.

Selecting a Location

The 7205 controller, like other networking and computing devices, requires the following “electronic-friendly” environment:

- Reliable power
 - Verify that the electrical outlet is compatible with the 7205 controller power supply.

- Cool, non-condensing ventilation
 - For proper operation, the 7205 controller requires an environment with an ambient air temperature between 0° C and 40° C (32° F and 104° F). Humidity must be kept at non-condensing levels, between 10% and 90%.
 - Where a large number of electrical devices are working in the same area, additional air conditioning or air circulation equipment may be required.
- Ample space
 - For proper air circulation, leave at least 10 cm (4 inches) clearance all around the chassis.
 - Leave additional space in front and rear side of the chassis to access power cords, network cables, and indicator LEDs.
- Limited electromagnetic interference
 - For best operation, keep the 7205 controller and all cords and cables at least 0.7 meters (2 feet) from fluorescent lighting fixtures, and 2 meters (6 feet) from photocopiers, radio transmitters, electric generators, and other sources of strong electromagnetic interference.

Rack Mounting - Standard/Front

This mounting option allows mounting the 7205 controller from the front in a standard two-post 19-inch Telco rack.



Each 7205 controller must have its own mounting equipment. Do not place other networking equipment directly on top of a mounted 7205 controller. Failure to do so can damage the controller.



Chaque contrôleur 7205 doit disposer de son propre équipement de montage. Veillez à ne placer aucun autre équipement réseau directement sur un contrôleur 7205 installé. Dans le cas contraire, vous risqueriez d'endommager le périphérique.

Required Tools and Equipment

The following tools and equipment are required for installing a 7205 controller:

- Mounting brackets (x2); Do not use for table or shelf installation
- Screws for the mounting brackets (x8): M4 x 8 mm Phillips Flat Head Screws
- Screws for system rack mount (x4): M6 x 15 mm Phillips Pan Head Screws
- Suitable screwdrivers (not included in the package)



Some racks require screws that differ from those included with the 7205 controller. Ensure to have the correct screws before installing the controller.

Installation Steps

To install a 7205 controller from the front in a standard two-post 19-inch Telco rack:

1. Place the mounting brackets over the mounting holes near the front on either sides of the controller (see [Figure 7](#)).

Figure 7 Attaching the Mounting Brackets

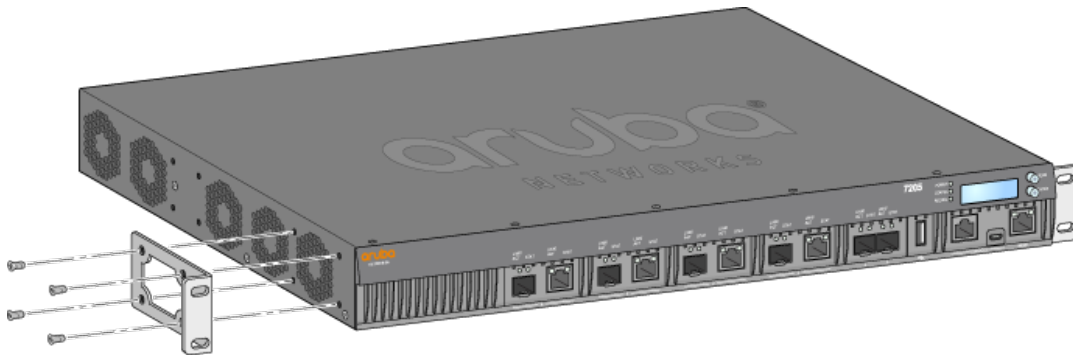

2. Secure the brackets to the controller using the eight screws for the mounting bracket (four per bracket) and a suitable screwdriver.
3. Mount the controller in the rack using the four screws for system rack mount (two per bracket) and a suitable screwdriver (see [Figure 8](#)).

Figure 8 Front-Rack Mount Installation

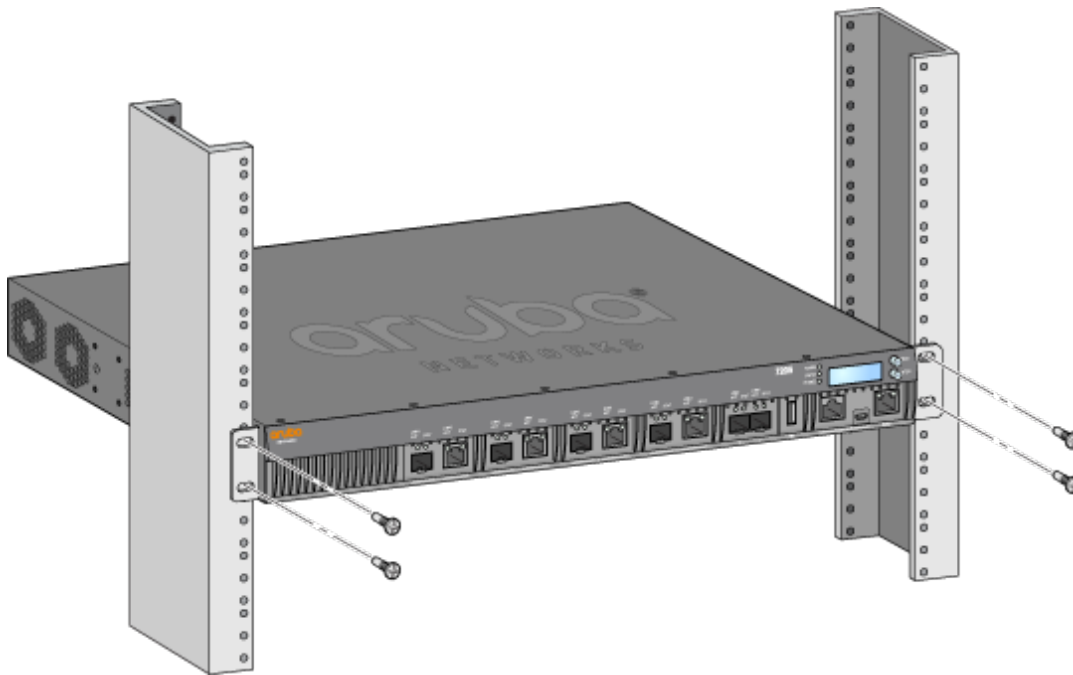

Leave a minimum of 10 cm (4 inches) of space on the left and right side of the controller for proper air flow and ventilation. Leave additional space in the front and the back of the controller to access network cables, LED status indicators, and power cord.

Rack Mount Installation- Mid

An optional accessory kit (SPR-WL2-MNT, must be purchased separately) is available that allows mounting the 7205 controller from the middle in standard two-post 19-inch Telco rack. For more information about this accessory kit, contact your Aruba sales representative.



Each 7205 controller must have its own mounting equipment. Do not place other networking equipment directly on top of a mounted 7205 controller. Failure to do so can damage the controller.



Chaque contrôleur 7205 doit disposer de son propre équipement de montage. Veillez à ne placer aucun autre équipement réseau directement sur un contrôleur 7205 installé. Dans le cas contraire, vous risqueriez d'endommager le périphérique.

Required Tools and Equipment

The following tools and equipment are required for installing a 7205 controller from the middle of the device:

- Mid-mount brackets (x2) (included in the mounting accessory kit)
- Screws for the mounting brackets (x8): M4 x 8 mm Phillips Flat Head Screws
- Screws for system rack mount (x4): M6 x 15 mm Phillips Pan Head Screws
- Suitable screwdrivers (not included in the package)



Some racks require screws that differ from those included with the 7205 controller. Ensure to have the correct screws before installing the 7205 controller.

Installation Steps

To install a 7205 controller from the middle in a standard two-point 19-inch rack system:

1. Place the mid-mount brackets over the mounting holes on either side of the controller in the middle (see [Figure 9](#)).

Figure 9 *Attaching the Mid-Mount Brackets*



2. Secure the brackets to the controller using the eight screws for mounting bracket (four per bracket) and a suitable screwdriver.
3. If the rack requires cage nuts or clip nuts, insert them on the front rails (two per rail, aligned horizontally)
4. Mount the controller in the rack using the four screws for system rack mount (two per bracket) and suitable screwdriver (see [Figure 10](#)).

Figure 10 *Mid-Mount Rack Installation*

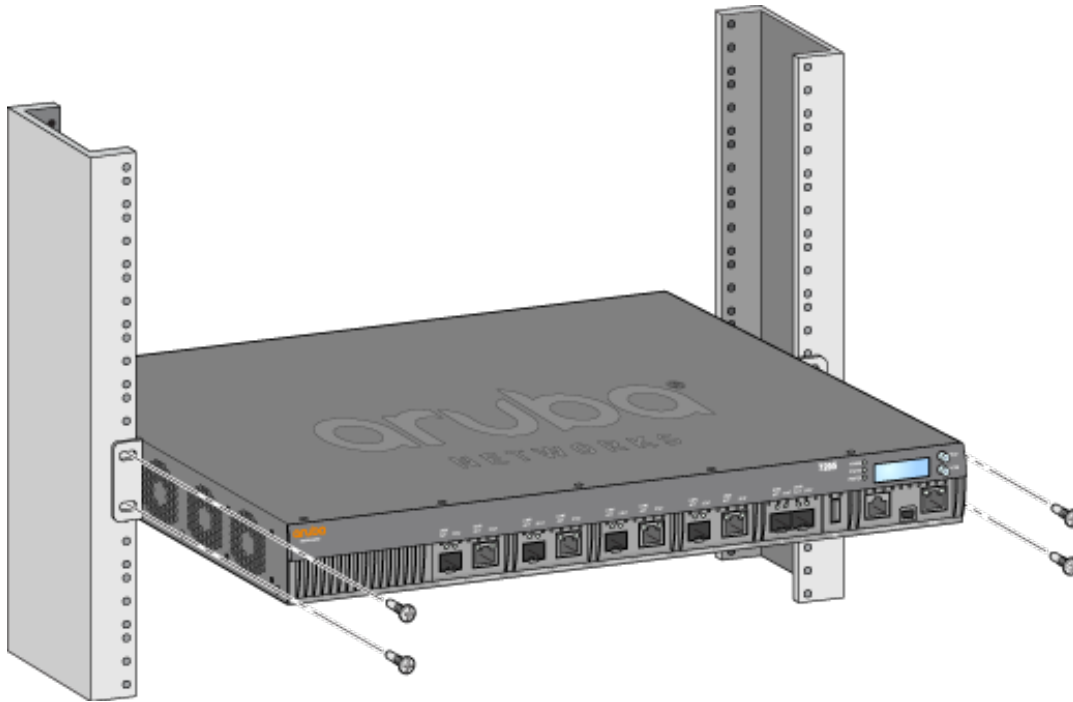

Leave a minimum of 10 cm (4 inches) of space on the left and right side of the controller for proper air flow and ventilation. Leave additional space in the front and the back of the controller to access network cables, LED status indicators, and power cord.

Table or Shelf Installation

Required Tools and Equipment

- Rubber feet (included in the package)

Installation Steps

1. Attach the rubber feet to the bottom of the controller (see [Figure 11](#)).
2. Place the controller on the desired flat table or shelf.

Figure 11 *Attaching Rubber Feet*

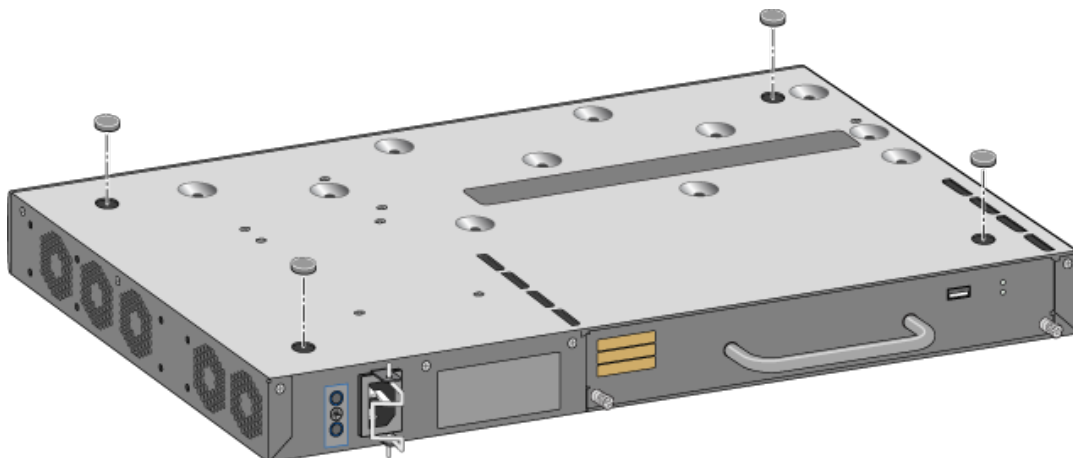

Wall Mounting

An optional accessory kit (SPR-WL2-MNT, must be purchased separately) is available that allows you to mount the 7205 controller to a wall. For more information about this accessory kit, contact your Aruba sales representative.

Required Tools and Equipment

The following tools and equipment are required for installing the 7205 controller on a wall:

- Wall-mount brackets (x2) (included in the mounting accessory kit)
- Screws for the mounting bracket (x8): M4 x 8 mm Phillips Flat Head Screws
- Wall anchors: Optional (not included in the package)
- Wall-mount screws (not included in this package, the type of screw depends on the installation surface)
- Suitable screwdrivers (not included in the package)

Installation Steps

To install a 7205 controller on a wall:



Ensure that the Ethernet ports are facing down when installing the 7205 controller on a wall.

1. Fasten the wall-mount brackets over the mounting holes on the sides of the controller using the eight screws for the mounting brackets (four per bracket) and a suitable screwdriver (see [Figure 12](#)).

Figure 12 *Attaching the Wall-Mount Brackets*



2. After choosing a mounting location, mark the points on the wall for the mounting holes.
3. Drill the holes and insert wall anchors if the installation requires them.
4. Align the holes of the mounting bracket with the holes drilled in the wall (see [Figure 13](#)).
5. Use appropriate screws to secure the controller.

Figure 13 *Wall-Mount Installation*

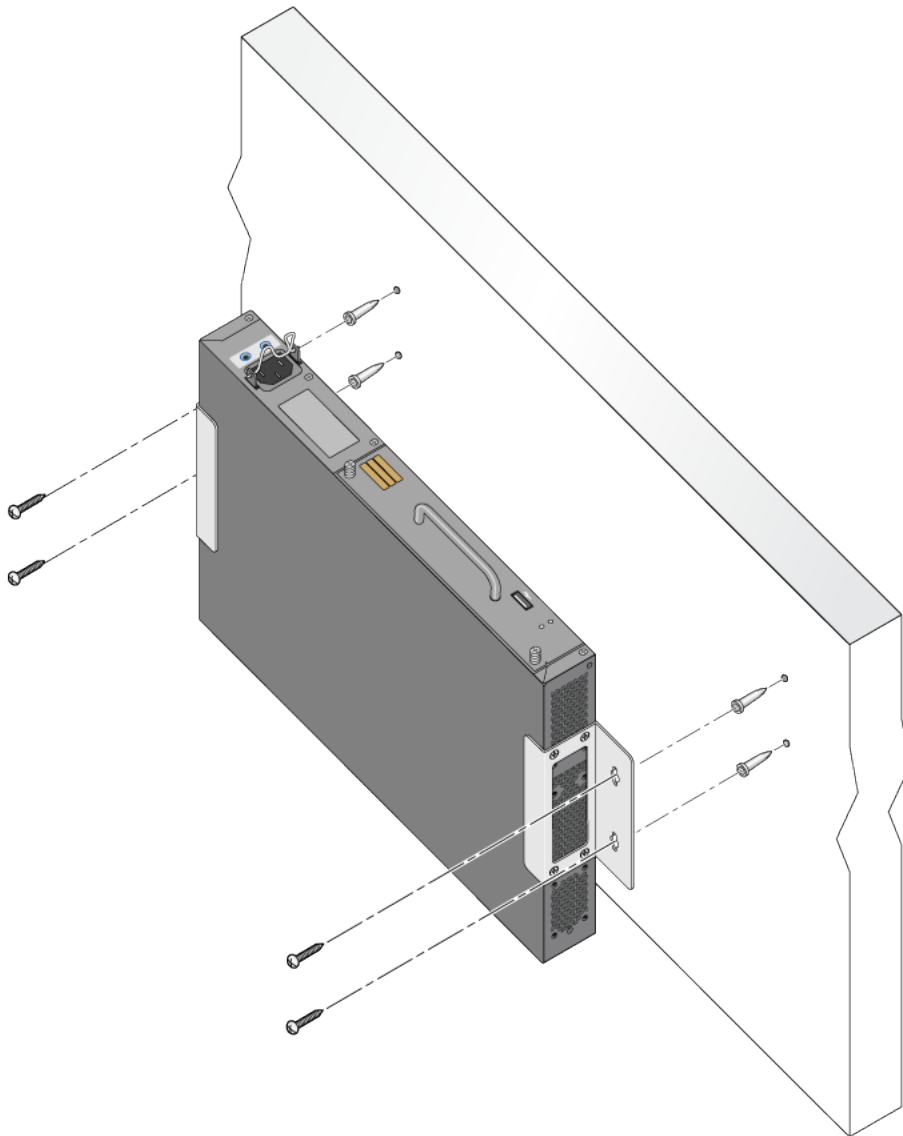

Connecting and Disconnecting the AC Power Cord

Once the controller is installed, it is ready to be powered on. The 7205 controller is not equipped with an On/Off switch. The controller will power On when the AC power cord is connected to the AC power connector and an AC power outlet.

Connecting the AC Power Cord

To connect the AC power cord to the 7205 controller:

1. Lift the power cord retaining clip so that it is not blocking the AC power connector.
2. Insert the coupler end of the AC power cord into the AC power connector.
3. Lower the power cord retaining clip over the AC power cord.

The 7205 controller should now be receiving power.

Disconnecting the AC Power Cord

To disconnect the AC power cord from the 7205 controller:

1. Lift the power cord retaining clip off the AC power cord.
2. Pull the AC power cord from the AC connector.
3. The 7205 controller is now turned Off.

Installing an SFP/SFP+ Module



Use standard ESD precautions when installing or removing an SFP/SFP+ module.

To install an SFP/SFP+ module into the 7205 controller:

1. Slide the SFP/SFP+ module, top side facing upward, into a 10GBASE-X or 1000BASE-X ports on the controller until a connection is made and an audible click is heard (see [Figure 14](#)).

Figure 14 *Installing an SFP Module*

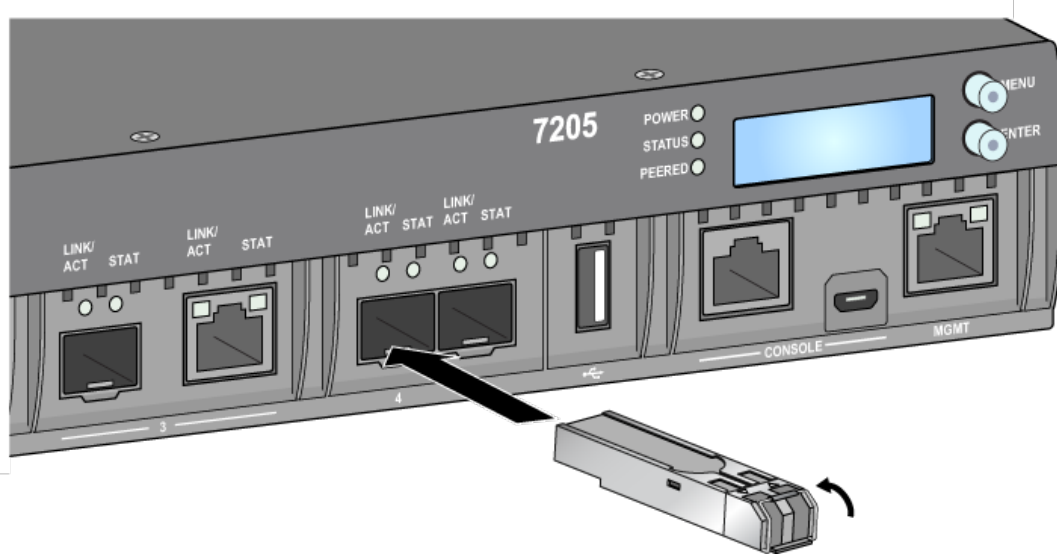

Connecting an LC Fiber Optic Cable

To connect an LC fiber optic cable into an SFP-SX or SFP-LX module:

1. Clean the fiber optic cable connector before inserting it into the SFP/SFP+ module.
2. Insert the fiber optic cable into the SFP/SFP+ module. Ensure that the latch on the cable faces the top of the SFP/SFP+ module (see [Figure 15](#)).
3. Slide the cable into place until a connection is made and an audible click is heard.

Figure 15 *Connecting an LC Fiber Optic Cable*

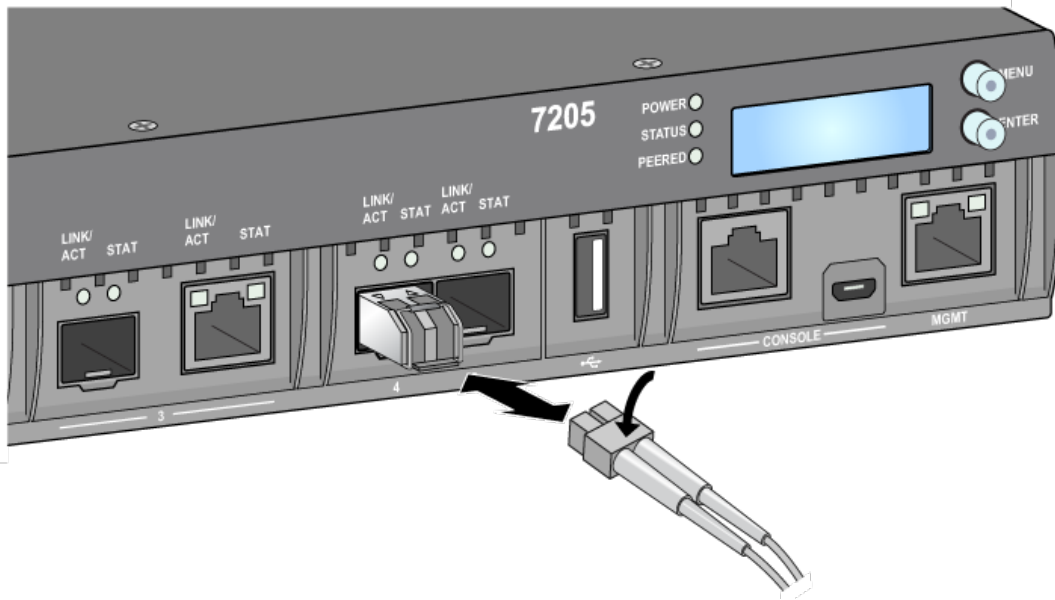

Disconnecting an LC Fiber Optic Cable

To disconnect an LC fiber optic cable from an SFP-SX or SFP-LX module:

1. Depress the transceiver handle to release the latch on the cable and simultaneously pull the cable out of the port.

Removing an SFP/SFP+ Module

To remove an SFP/SFP+ module:

1. Open and release the latch on the SFP/SFP+ module.
2. Pull and remove the module from the port.

7205 Specifications

Physical

- Device Dimensions (without mounting brackets) (HxWxD): 1.72" x 17.40" x 13.15" (4.37 cm x 44.2 cm x 33.40 cm)
- Device Weight: 10.912 lbs (4.95 kgs)

Power Supply Specifications

- 180 W AC Power Supply
 - AC Input Voltage: 100 VAC to 240 VAC
 - AC Input Current: 2.2 A
 - AC Input Frequency: 50 to 60 Hz

Operating Specifications

- Operating Temperature Range: 0 °C to 40 °C (32 °F to 104 °F)
- Operating Humidity Range: 10% to 90% (RH), non-condensing

Storage Specifications

- Storage Temperature Range: 0 °C to 50 °C (32 °F to 122 °F)
- Storage Humidity Range: 10% to 95% (RH), non-condensing

Safety and Regulatory Compliance

Aruba Networks, Inc. provides a multi-language document that contains country-specific restrictions and additional safety and regulatory information for all Aruba products. This document can be viewed or downloaded from the following location: www.arubanetworks.com/safety_addendum



The Aruba controllers must be installed by a professional installer. The professional installer is responsible for ensuring that grounding is available and it meets applicable local and national electrical codes.



Les contrôleurs Aruba doivent être installés par un installateur professionnel. Cet installateur doit s'assurer que ces appareils sont correctement mis à la terre et que le circuit de mise à la terre est conforme aux codes électriques locaux et nationaux en vigueur.



Use of controls or adjustments of performance or procedures other than those specified in this manual may result in hazardous radiation exposure.



L'utilisation de commandes ou de réglages de performances ou de procédures qui ne sont pas spécifiées dans ce manuel risque d'entraîner une exposition à des rayonnements dangereux.

This product complies with 21 CFR Chapter 1, Subchapter J, Part 1040.10, and IEC 60825-1: 1993, A1: 1997, A2: 2001, IEC 60825-2: 2004+A1.

For continued compliance with the above laser safety standards, only approved Class 1 modules from our approved vendors should be installed in the product.



Although this controller has been tested up to 1 kV per CE immunity requirements, this product requires surge protection to be provided as part of the building installation to protect against unidirectional surges resulting from electrical switching and lightning strikes. For protection against these surges in an outdoor installation, any exposed wiring must be shielded, and the shield for the wiring must be grounded at both ends.



Le contrôleur a été testé jusqu'à 1 000 V conformément aux exigences en matière d'immunité de la Communauté européenne. Cependant, il est essentiel de prévoir une protection contre les surtensions dans l'installation électrique du bâtiment afin de protéger l'appareil contre les surtensions unidirectionnelles provenant du circuit électrique ou de la foudre. Pour se protéger contre ces surtensions dans une installation extérieure, tous les câbles exposés doivent être blindés et le blindage doit être mis à la terre aux deux extrémités.

Regulatory Model Name

The regulatory model name for the 7205 controller is ARCN7205.

Electromagnetic Interference

United States

This equipment has been tested and found to comply with the limits for a Class A digital device, pursuant to Part 15 of the FCC Rules. These limits are designed to provide reasonable protection against harmful interference when the equipment is operated in a commercial environment. This equipment generates, uses, and can radiate radio frequency energy and, if not installed and used in accordance with the instruction manual, may cause harmful interference to radio communications. Operation of this equipment in a residential area is likely to cause harmful interference in which case the user will be required to correct the interference at their own expense.

Any changes or modifications not expressly approved by the party responsible for compliance could void the user's authority to operate this equipment.

This product complies with Part 15 of the FCC Rules. Operation is subject to the following two conditions: (1) this device may not cause harmful interference, and (2) this device must accept any interference received, including interference that may cause undesired operation.

Canada

This digital apparatus does not exceed the Class A limits for radio noise emissions from digital apparatus as set out in the interference-causing equipment standard entitled "Digital Apparatus," ICES-003 of the Department of Communications.

Cet appareil numérique respecte les limites de bruits radioélectriques applicables aux appareils numériques de Classe A prescrites dans la norme sur le matériel brouilleur: "Appareils Numériques," NMB-003 édictée par le ministère des Communications.

Europe



This is a Class A product. In a domestic environment, this product may cause radio interference in which case the user may be required to take adequate measures.



Produit de classe A. Dans un environnement domestique, ce produit peut provoquer des interférences radio, auquel cas l'utilisateur doit prendre un certain nombre de mesures.

This product complies with EN55022 Class A and EN55024 standards.

Japan VCCI

この装置は、クラスA 情報技術装置です。この装置を家庭環境で使用すると電波妨害を引き起こすことがあります。この場合には使用者が適切な対策を講ずるよう要求されることがあります。 VCCI- A

This is a Class A product. In a domestic environment this product may cause radio interference in which case the user may be required to take corrective actions.

Taiwan (BSMI)

警告使用者：
這是甲類的資訊產品，在居住的環境中使用時，可能會造成射頻干擾，在這種情況下，使用者會被要求採取某些適當的對策。

South Korea

이 기기는 업무용(A급) 전자파 적합기기로서 판매자 또는 사용자는 이 점을 주의하시기 바라며, 가정외의 지역에서 사용하는 것을 목적으로 합니다.

EU Regulatory Conformance

CE **ⓘ** This product is CE marked according to the provisions of the EMC Directive (2004/108/EC) - CE. Aruba, hereby declares that 7205controller device models are in compliance with the essential requirements and other relevant provisions of Directive (2004/108/EC) – CE. The Declaration of Conformity made under Directive 1999/5/EC is available for viewing in the EU community.

Battery Statements



The battery supplied with this product may contain perchlorate material. Special handling may apply in California and other certain states. See www.dtsc.ca.gov/hazardouswaste/perchlorate for more information.



La batterie fournie avec ce produit peut contenir du perchlorate. Des précautions de manipulation peuvent s'appliquer dans l'État de Californie et dans d'autres états/pays. Consultez la page www.dtsc.ca.gov/hazardouswaste/perchlorate pour plus d'informations.



Risk of explosion if battery is replaced by an incorrect type. Dispose of used batteries according to the instructions.



Risque d'explosion si la batterie est remplacée par une batterie de type incorrect. Mettez les batteries au rebut conformément aux instructions.

Proper Disposal of Aruba Equipment

Waste of Electrical and Electronic Equipment



Aruba products at end of life are subject to separate collection and treatment in the EU Member States, Norway, and Switzerland and therefore are marked with the symbol shown at the left (crossed-out wheeled bin). The treatment applied at end of life of these products in these countries shall comply with the applicable national laws of countries implementing Directive 2012/19/EU on Waste of Electrical and Electronic Equipment (WEEE).

China RoHS



Aruba products also comply with China environmental declaration requirements and are labeled with the "EFUP 50" label shown at the left.

有毒有害物质声明 Hazardous Materials Declaration

部件名称 (Parts)	有毒有害物质或元素 (Hazardous Substances)					
	铅 Lead (Pb)	汞 Mercury (Hg)	镉 Cadmium (Cd)	六价铬 Chromium VI Compounds (Cr ⁶⁺)	多溴联苯 Polybrominated Biphenyls (PBB)	多溴二苯醚 Polybrominated Diphenyl Ether (PBDE)
电路板 PCA Board	X	○	○	○	○	○
机械组件 Mechanical Subassembly	X	○	○	○	○	○
电源适配器 Power Adaptor	X	○	○	○	○	○
O: 表示该有毒有害物质在该部件所有均质材料中的含量均在SJ/T11363-2006标准规定的限量要求以下。 This component does not contain this hazardous substance above the maximum concentration values in homogeneous materials specified in the SJ/T11363-2006 Industry Standard.						
X: 表示该有毒有害物质至少在该部件的某一均质材料中的含量超出SJ/T11363-2006标准规定的限量要求。 This component does contain this hazardous substance above the maximum concentration values in homogeneous materials specified in the SJ/T11363-2006 Industry Standard.						
对销售之目的所售产品, 本表显示, 供应链的电子产品信息产品可能包含这些物质。 This table shows where these substances may be found in the supply chain of electronic information products, as of the date of sale of the enclosed product.						
此标志为针对所涉及产品的环保使用期标志。 某些零部件会有一个不同的环保使用期(例如, 电池单元模块)贴在其产品上。 此环保使用期只适用于产品是在产品手册中所规定的条件下工作。 The Environment-Friendly Use Period (EFUP) for all enclosed products and their parts are per the symbol shown here. The Environment-Friendly Use Period is valid only when the product is operated under the conditions defined in the product manual.						



Part Number: 0510304-01

European Union RoHS

RoHS Aruba products also comply with the EU Restriction of Hazardous Substances Directive 2011/65/EU (RoHS). EU RoHS restricts the use of specific hazardous materials in the manufacture of electrical and electronic equipment. Specifically, restricted materials under the RoHS Directive are Lead (including Solder used in printed circuit assemblies), Cadmium, Mercury, Hexavalent Chromium, and Bromine. Some Aruba products are subject to the exemptions listed in RoHS Directive Annex 7 (Lead in solder used in printed circuit assemblies). Products and packaging will be marked with the "RoHS" label shown at the left indicating conformance to this Directive.

India RoHS

This product complies with RoHS requirements as prescribed by E-Waste (Management & Handling) Rules, governed by the Ministry of Environment & Forests, Government of India.

